

► **Code Number:**

3250403

► **Description**

Exposed, Battery Powered, Sensor Operated Urinal Flushometer.

► **Flush Cycle**

- 1.5 gpf / 5.7 lpf

Specifications

Quiet, Exposed, Diaphragm Type, Chrome Plated Urinal Flushometer for either left or right hand supply with the following features:

- Spud Coupling and Flange for 1 1/2" Top Spud
- Flush Accuracy Controlled by CID Technology
- Spud Coupling and Flange for 3/4" Top Spud
- Sweat Solder Adapter with Cover Tube and Cast Set Screw Wall Flange
- Handle Packing, Main Seat, Stop Seat and Vacuum Breaker Molded from PERMEX® Rubber Compound for Chloramine resistance
- Infrared Sensor with Multiple-focused, Lobular Sensing Fields for high and low target detection
- Initial Set-up Range Indicator Light (first 10 minutes)
- "Low Battery" Flashing LED
- ADA Compliant Battery Powered Infrared Sensor for automatic "No Hands" operation
- Infrared Sensor with Multiple-focused, Lobular Sensing Fields for high and low target detection
- Latching Solenoid Operator
- Fixed Metering Bypass and No External Volume Adjustment to Ensure Water Conservation
- Flex Tube Diaphragm designed for improved life and reduced maintenance
- Engineered Metal Cover with replaceable Lens Window
- Courtesy Flush® Override Button
- Four (4) Size AA alkaline Batteries included: Duracell® with DURALOCK Power Preserve Technology™-guaranteed for up to 10 years in storage
- 3/4" I.P.S. Screwdriver Bak-Chek® Straight Stop with Free Spinning, Vandal Resistant Stop Cap

Valve Body, Tailpiece and Control Stop shall be in conformance with ASTM Alloy Classification for Semi-Red Brass. Valve shall be in compliance with the applicable sections of ASSE 1037, ANSI/ASME A112.19.2. Installation conforms to ADA requirements.

Accessories (Sold Separately)

- See Accessories Section and OPTIMA Accessories Section of the Sloan catalog for details on these and other Optima Plus Flushometer variations.

Control Circuit

- Solid State

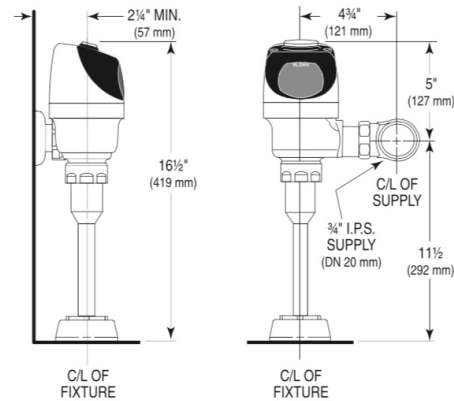

Automatic Operation

Sloan G2 Optima Plus Flushometers activate via multi-lobular sensor detection to provide the ultimate in sanitary protection and automatic operation. A battery powered infrared sensor sets the flushing mechanism after the user is detected and completes the flush when the user steps away.

Functional & Hygienic

Touchless, sensor operation eliminates the need for user contact to help control the spread of infectious diseases. The G2 Optima Plus Flushometer is provided with an Override Button to allow a "courtesy flush" for individual user comfort.

Economical

Sloan installed batteries speed installation and provide years of metered flushing to control the use of water and energy. Batteries can be changed without turning off the water.

► **Compliance & Certifications**



This space for Architect/Engineer Approval

- 6 VDC Input
- 8 Second Arming Delay
- 24 Hour Sentinel Flush

Sensor Type

- Active Infrared

Sensor Range

- Nominal 15" - 30" (381 mm - 762 mm), Adjustable \pm 8" (203 mm)

Battery Type

(4) Size AA Alkaline: Duracell® with DURALOCK Power Preserve Technology™

Battery Life

- 6 Years @ 4,000 Flushes/Month

Indicator Lights

- Range Adjustment

Operating Pressure

- 15 - 100 psi (104 - 689 kPa)

Sentinel Flush

- Once Every 72 Hours After the Last Flush. Product shipped from factory with feature turned off. Consult factory to activate.

► ROUGH-IN

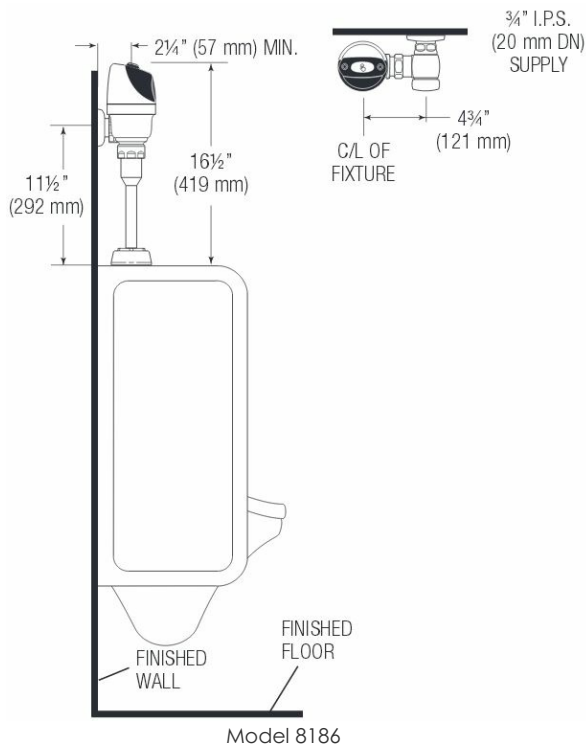

Note: Lens Deflector no longer needed for targeting children or wheel chair users.

Typical Urinal Installation

All information contained within this document subject to change without notice.

► OPERATION

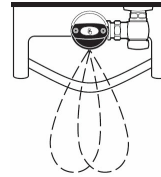

1. A continuous, invisible light beam is emitted from the Sensor.

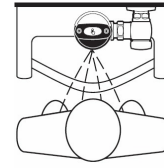

2. As the user enters the beam's effective range (15" to 30") the beam is reflected into the Scanner Window and transformed into a low voltage electrical circuit.

Once activated, the Output Circuit continues in a "hold" mode for as long as the user remains within the effective range of the Sensor.

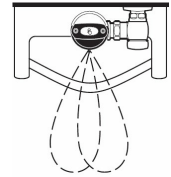

3. When the user steps away from the Sensor, the Sensor initiates an electrical signal that operates the Solenoid. This initiates the flushing cycle to flush the fixture. The Circuit then automatically resets and is ready for the next user.